

Precision Flow Measurement

featuring



HighBeta®



Air Flow Products Catalog

EASTERN INSTRUMENTS

Table of Contents

Our Facilities: Measuring Up to the Highest Standards	3
About Eastern Instruments	3
About the VAP ³ ®/SA, VAP ³ ®/PA, and High Beta®	4
Engineered Solutions	5
Measuring air flow is easy	6
How can air flow measurement systems from EI help me?	8
VAP ³ ® Series and High Beta® Series Applications	8
VAP ³ ® Series	9
VAP ³ ® Series Specifications	10
High Beta® Systems	14
High Beta® Specifications	15
Air Flow System Installation	16
Determining Upstream Mounting Requirements	16
Determining Downstream Mounting Requirements	17
Remote Electronics Packages	19
DPS: Differential Pressure System	19
DPU: Differential Pressure Unit	19
DPG: Differential Pressure Gauge	19
Other Options	22
Line Mounted Purge (LMP)	22
VAP ³ ® Insertion Port with Blank-Off Plate (VIP)	22
Remote Temperature Sensor (RTS)	22

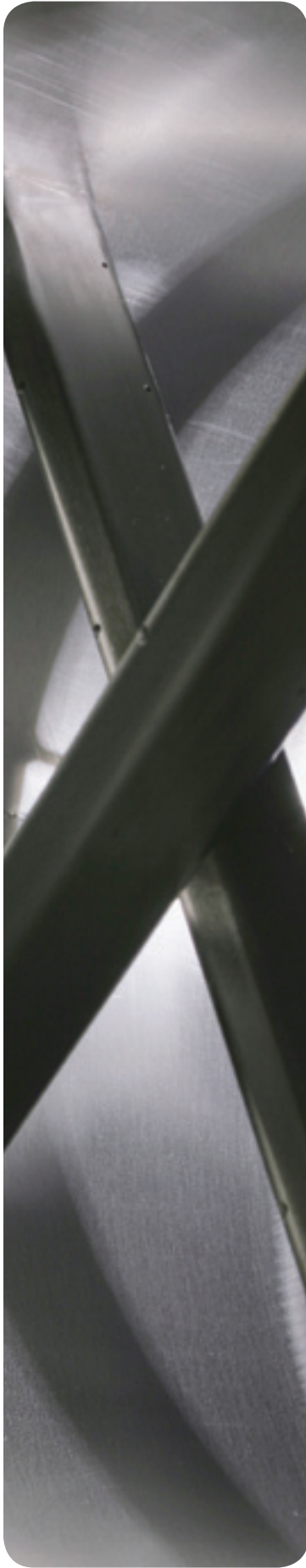

Our Facilities: Measuring Up to the Highest Standards

To help us achieve – and set – the highest standard of air flow measurement, Eastern Instruments maintains 26,000 sq. ft. of engineering, laboratory, testing, and assembly area in two Wilmington locations. There are two stand-alone laboratory sites, one of which is a test facility with an air flow test chamber with *NIST referenced nozzles. Within the main building, which houses the general offices and engineering organization, are a fully supported machine shop, fabrication services, electronics assembly, and testing department.



High Beta® devices manufactured for the process industry can be tested using our air flow chamber. The tests are to validate High Beta® design and VAP3® pitot array performance under real and simulated conditions. Nearly all High Beta® units for the power generation industry are engineered to order and are designed by our Engineering Department. See page 5 for additional information about Eastern Instruments' Engineering Solutions.



**National Institute of Standards and Technology*

About Eastern Instruments

Eastern Instruments, a Certified Women's Business Enterprise, is an engineered solutions company located adjacent to the North Carolina International State Port in Wilmington. Since 1984, we have been engaged in the design and manufacture of engineered-to-order air flow measuring and control systems for clients around the globe. These devices are built into systems that regulate and perform critical process functions. These systems provide a high degree of accuracy combined with simplicity of installation, operation and maintenance for both the power and process industries.



**EASTERN
INSTRUMENTS**

416 Landmark Drive
Wilmington, NC 28412
Phone: 910.392.2490
Fax: 910.392.2123
www.easterninstruments.com

Precision Flow Measurement

Welcome to Eastern Instruments

About the VAP³[®]/SA

A proprietary design for relatively clean air applications and for Superior Accuracy (SA), the VAP³[®]/SA air flow measurement pitots are ideal for either new or retrofit process applications. When inserted in air flow ducts, the VAP³[®]/SA provides an accurate, differential pressure output allowing for precise air flow measurement and control of your process to as low as $\pm 0.50\%$ when calibrated. The VAP³[®]/SA pitots can also be incorporated within flow-conditioning devices, such as the High Beta[®], designed for short duct run applications with turbulent air flow, or to obtain the maximum accuracy.



About the VAP³[®]/PA

A proprietary design for Particulate-laden applications (PA), the VAP³[®]/PA air flow measurement pitots are ideal for either new or retrofit process and power generation applications. When inserted in air flow ducts, the VAP³[®]/PA provides an accurate, differential pressure output allowing for precise air flow measurement and control of your process to as low as $\pm 2\%$ when calibrated, utilizing a plug-resistant design. The VAP³[®]/PA pitots can also be incorporated within flow-conditioning devices, such as the High Beta[®], designed for short duct run applications with turbulent air flow, or to obtain the maximum accuracy.



About the High Beta[®]

The High Beta[®] is a proprietary-designed flow-conditioning device with minimal pressure loss which accepts VAP³[®] Pitots and was designed for installations with relatively few or almost no duct runs upstream and/or downstream. The High Beta[®] eliminates cyclonic, turbulent, and reverse flow at the point of measurement. It is ideal for both new or retrofit process and power applications where insufficient straight duct runs are present and/or accuracy is required. The High Beta[®] allows the VAP Pitots to obtain their maximum accuracy.

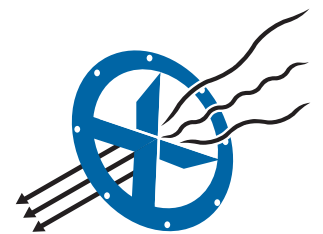

HighBeta[®]

Additionally, the High Beta[®] can be *NIST reference calibrated prior to installation. Typical *NIST calibrated total flow uncertainties can be as low as $\pm 0.50\%$ over the calibrated range. There are many different variations of the High Beta[®] that include specific product features for the pharmaceutical, process, and power generating industries. The High Beta[®] can also be engineered to meet specific application requirements. Read on to discover which High Beta[®] options are right for your application.

**National Institute of Standards and Technology*

FOR MORE INFO, CALL 910.392.2490

Engineered Solutions

Engineering is the heart of Eastern Instruments. From its beginning as a consulting firm to producing today's full-scale systems, EI has built a solid reputation solving complex air flow problems for customers in the process and power generation industries. Our VAP3® Pitots and High Beta® flow conditioners, whether installed as a device or part of an EI-built process system, reflect our dedication to providing the best-engineered products possible for the customer's application to improve measurement accuracy and process performance.

Engineering services include:

- Computational Fluid Dynamics (CFD) modeling to optimize ductwork and placement of air flow measurement devices
- Thermo Fluid, Structural (including natural frequency and resonance), Dynamic, and Finite Element Analysis
- 3-D Analysis and Process Modeling
- Simulation of Flow: Liquids and Gases
- Heat and Mass Transfer Analysis
- Drying Analysis
- Thermal Stratification/Mixing Modeling for air duct optimization
- Documented traceability (Fan Certification – even for Large Fans)

Engineered solutions include:

- Heated VAP3® Pitots
- VAP3®/XL Pitots for Large Ducts (up to 20 feet in diameter) utilizing VAP3® Cross Sectional design
- High Beta® Flow-conditioning Device utilizing VAP3®/XL Pitots for Large Ducts

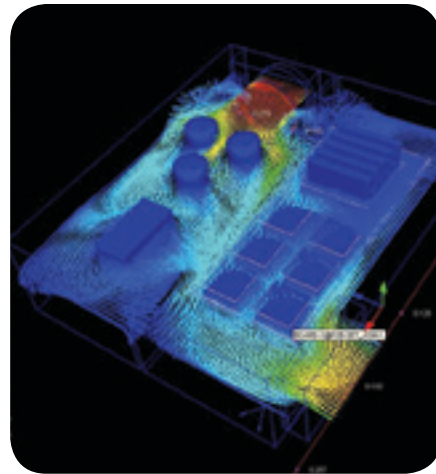

CFD Modeling

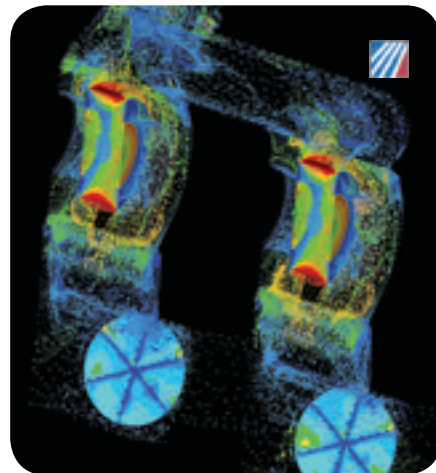

CFD Modeling showing VAP3® Pitot Array

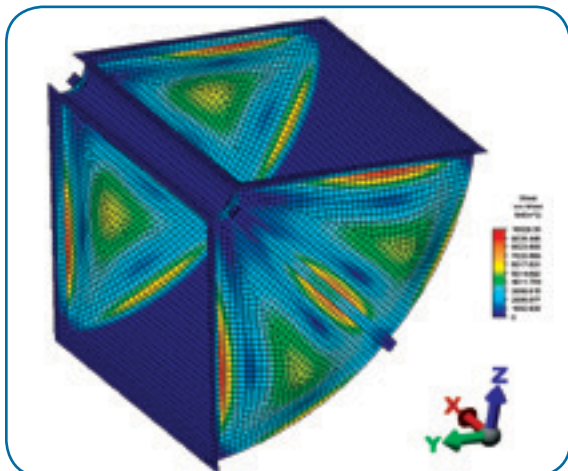

Structural Analysis

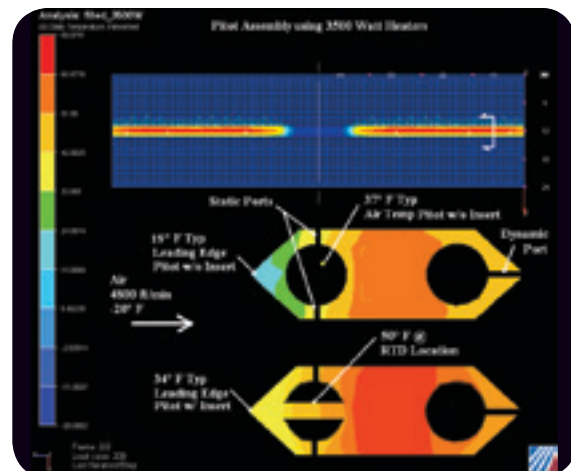

Heat Analysis

Measuring air flow is easy. Measuring it accurately is another story.

Environments where air flow measurement that is not repeatable, accurate, or representative of mass flow will destabilize the air flow control loop. The growing trend to improve plant efficiency in today's process and power generation makes accurate air flow measurement crucial. Eastern Instruments' proprietary-designed VAP³[®] Pitots and High Beta[®] flow-conditioning device combat the primary causes of inaccurate air flow measurement and provide accurate and reliable measurement solutions.

Why choose pitot measurement technology by Eastern Instruments?

Pitot tubes are not only a time-tested method of measuring air flow in ducts, but are cost-effective, easily maintained, and applicable to a variety of duct configurations. A significant advantage of pitot tubes over venturi, orifice plates, and airfoils is the minimal unrecovered pressure drop across the flow element, which equals cost savings.

VAP³[®]/SA Pitot: Tired of chasing K Factors?

The VAP³[®]/SA Pitot is a multi-ported averaging device designed to be mounted within a duct or within the High Beta[®] flow-conditioning device. The accuracy of the VAP³[®]/SA Pitot, particularly when used in a flow-conditioning device, such as the High Beta[®], is unparalleled. On flow rates as high as 1,000,000 lb/hr, when referenced to *NIST sonic nozzles, comparison over the operating range is typically $\pm 0.50\%$. When corrected for flow, the comparison to the reference can be improved to better than $\pm 0.15\%$.

**National Institute of Standards and Technology*



Eastern Instruments' VAP³[®] pitots

VAP³[®]/PA Pitot: Make flow element blockages history

In most cases, pitot tubes have one port facing into the air stream and one port at 90° to the air stream. The differential pressure between this "high" and "low" port represents the velocity. The port facing the air stream (impact port) is vulnerable to plugging from airborne particulate. Some manufacturers offer high flow purge systems that periodically blow out the ports. Purge systems are costly, add complexity to the measurement, are prone to plugging, and have high failure rates over time. A notable exception to the plugging problem is the VAP³[®]/PA Pitot design from Eastern Instruments. The VAP³[®]/PA pitot places its "high" port in line with the air flow, which means it has no impact ports and is resistant to plugging. Very few applications require purge systems.

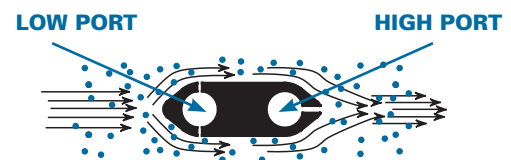

A cross section of the VAP³[®]/PA Pitot Tube, demonstrating resistance to plugging



Detail of VAP³ Pitots installed in a High Beta[®] flow conditioner

High Beta[®]: Insufficient straight runs? Not a problem

Typical flow measurement devices require sufficient upstream and downstream duct runs for accurate measurement. In most applications, there are rarely sufficient straight runs to permit accurate measurements. To reduce the straight-run requirements, flow straighteners are often used to achieve balanced flows free of cyclonic and turbulent conditions. These devices can be effective, but they are not without cost.

Honeycomb-style flow straighteners can cause an unacceptable pressure drop upstream of the measurement due to plugging. Custom duct inserts, while effective, typically do not settle cyclonic flow and are expensive to install. The solution?

Enter the High Beta[®], which integrates the flow-straightening vanes and a flow-profiling section with VAP³ Pitots into a precise cross sectional area that yields minimal pressure drop and optimal accuracy. It is easily installed, adds structural integrity, and is not susceptible to breaking or plugging.

High Beta[®]: Better consistency

Rectangular ducts always expand and contract. As duct pressure increases, the walls of a rectangular duct tend to bow. This change in effective duct area

That's where Eastern Instruments' technology excels.

can severely impact flow measurement because mass calculations inferred by velocity depend on constant duct cross-sectional area. The High Beta[®] creates a rigid, non-moving cross-sectional area of duct with an integrated flow profiling design.

Flow straightening and profiling through a converging section allows the High Beta[®] to be mounted where conventional measurements cannot be effective. The High Beta[®] can be accurate when placed directly downstream of an elbow, damper, or other obstruction with minimal pressure loss.

Don't forget the variables

As with all differential pressure-based measurements, velocity signals must compensate for temperature and duct static pressure. Temperature compensation is accomplished through direct measurement of air temperature (Thermocouple or RTD), and the transmission of that measurement to the DCS or to a compensating transmitter. Pressure compensation is accomplished through measurement to an absolute pressure transmitter. The Differential Pressure System (DPS) from Eastern Instruments is capable of using all three inputs to accurately calculate a density compensated mass flow.

The conclusion?

While obtaining air flow measurement is relatively easy, obtaining an accurate, repeatable signal can be challenging – and accurate measurements are essential to system efficiency. The High Beta's[®] combination of integrated flow straighteners, converging section, constant cross-sectional measurement area and plug-resistant VAP³/PA pitots makes the most cost-effective, accurate, repeatable air flow measurement technology in the process and power generation industries. The choice is simple. Choose Eastern Instruments.

How can air flow measurement systems from EI help me?

Eastern Instruments offers a complete line of air and gas flow measurement systems based on more than 35 years of pitot development and product improvements. Our technical director, Bob Brandt, is widely regarded as a first-rank expert on the subject of air flow measurement and pitot tube design. Whether you need to increase boiler efficiency or obtain an optimized fluidized velocity for a fluid bed dryer, rest assured that Eastern Instruments can provide you with a system that will fit your needs.



VAP³® Series Applications

Process Applications

- Fluid Bed Dryers
- Pneumatic conveyance systems
- Process Exhaust Systems
- Scrubbers

Power Plant Applications

- Waste-to-Energy
- Overfire Air
- Underfire Air
- Tertiary Air
- Individual Burner Flow



High Beta[®] Applications

Boiler Systems

- Cyclone Furnace
- Single Wall Furnace
- Dual Walled Furnace
- Turbo Dry Bottom Furnace
- Tangentially fired furnace
- Circulating Fluidized Bed Furnace

Coal-fired

- Primary Air
- Secondary Air
- Stack (Flue Gas) Flow
- Tempering Air
- Overfire Air

Oil-fired

- Primary Air
- Secondary Air
- Stack Flow

Waste-to-Energy

- Overfire Air
- Underfire Air
- Individual Burner Flow
- Stack Flow

Nuclear

- HVAC

Process

- Fluid Bed Dryers
- Pneumatic conveyance systems
- Process Exhaust Systems
- Scrubbers



IDEAL FOR PROCESS AND POWER GENERATION INDUSTRIES

The VAP³[®] Series: Velocity Averaging Parallel Plate Pitots

VAP³[®] Pitots have a unique Velocity Averaging and Parallel Plate proprietary design. When inserted in air flow ducts, the VAP³[®] Pitots provide an accurate, differential pressure output allowing for precise air flow



measurement or control of your process. VAP³[®] Pitots are designed for Superior Accuracy (SA) for clean air applications or plug resistant (PA) for heavy particulate-laden applications. The VAP³[®] Pitots can be installed in existing or new ducts or incorporated into flow-conditioning devices, such as the High Beta[®], designed for short duct run applications with turbulent air flow or to obtain optimal accuracy.

Each VAP³[®] Pitot has multiple total and static sensing ports, specifically located to provide a full traverse of the duct, thus eliminating the concern of highly random distribution of air flow. For larger ducts, an array of pitots, with total and static pressure lines manifolded, can be installed to ensure an equal area traversing and fully averaged air flow sampling. The VAP³[®] Pitots are erosion resistant and can handle typical process temperatures from -40° to 700°F. Other engineered options are available for temperatures outside this range. The VAP³[®] Pitots are constructed from a single-piece series 6063 aluminum extrusion that

has a Teflon[®] (DuPont) impregnated hard-anodizing metallurgical surface treatment applied, yielding a surface hardness of Rockwell 65C.

Features and Benefits

- **VAP³[®]/SA = Superior Accuracy:** No K Factor required (Flow coefficient is not Reynolds number dependent)
- **VAP³[®]/PA = Particulate-laden Applications:** No impact ports, plug resistant design
- **Parallel plate cross sectional design:** Minimizes turbulence at the sensing ports, preventing particulate build up
- **Multiple differential pressure-sensing ports:** Velocity averaging throughout the full traverse of duct
- **Pitot Array:** Full duct coverage
- **Teflon[®] hard anodized 6063 aluminum extrusion:** Rockwell Hardness 65C; High temperature range
- **High turn-down:** Broad process range
- **Integrated temperature element available:** Reduced in-duct obstructions
- **Large Duct Installations:** VAP³[®]/XL Pitots (up to 240 inches)
- **Engineered Solutions:** Heated Pitots, High Velocities, and much more to meet customer specific needs

YOUR CHOICE OF APPLICATIONS

VAP³[®]/SA (Superior Accuracy)

Ideally designed to provide accurate differential pressure outputs for precise air flow measurement in process applications, the VAP³[®]/SA is suitable for relatively clean process environments (such as clean flows or filtered gas streams), where high accuracy is required for measurement and control.

VAP³[®]/PA (Particulate Application)

VAP³[®]/PA is designed for particulate-laden applications. Can be placed in heavily particulate/condensate-laden environments while still measuring accurately and reliably without being prone to plugging problems.

VAP³® SERIES SPECS

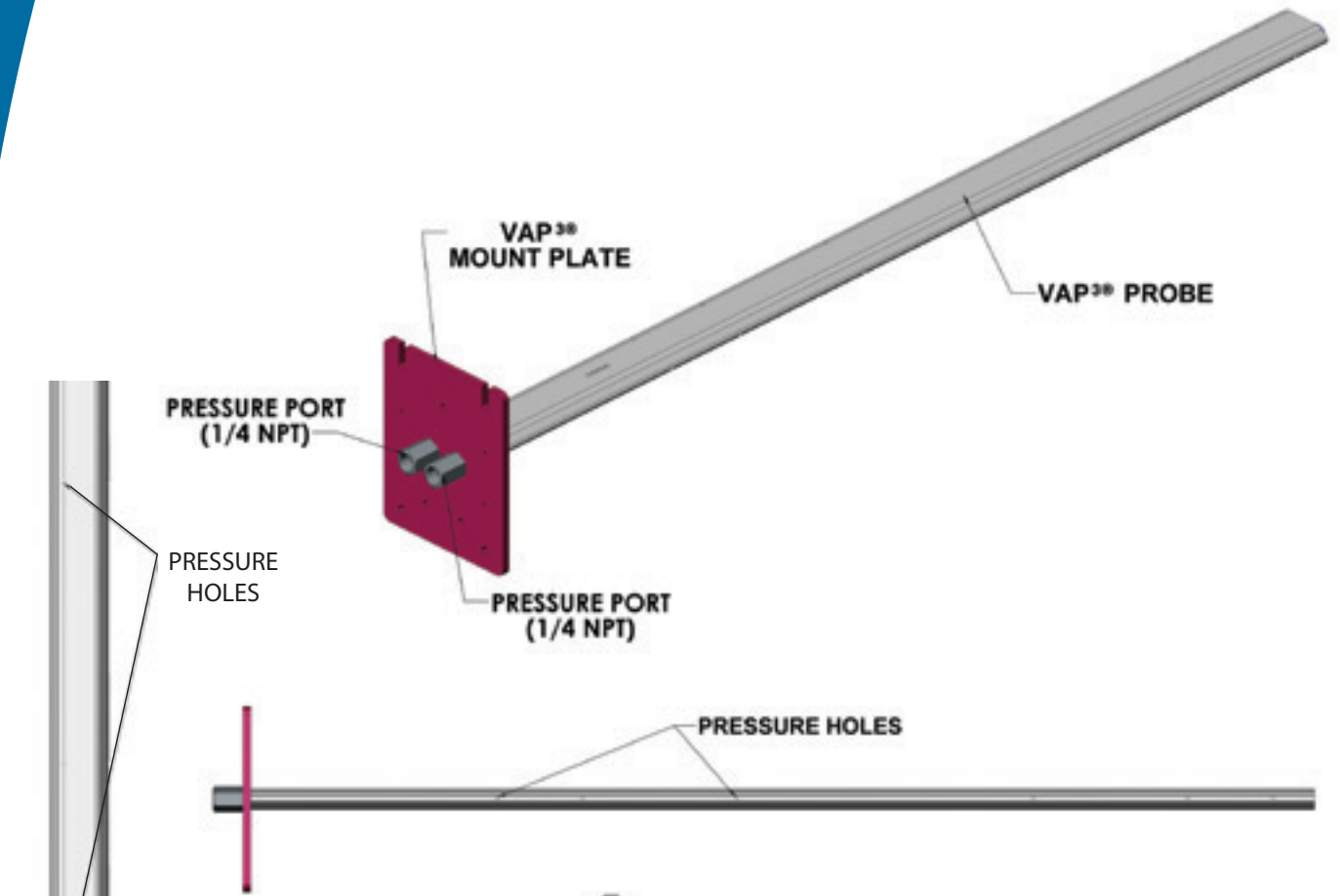

**VAP³ Pitots
Circular Duct
Installation
(front view)**



DIM	Probe Sizes	
	4 - 20	Over 20
A	4.25 in	6.25 in
B	4.95 in	2.95 in

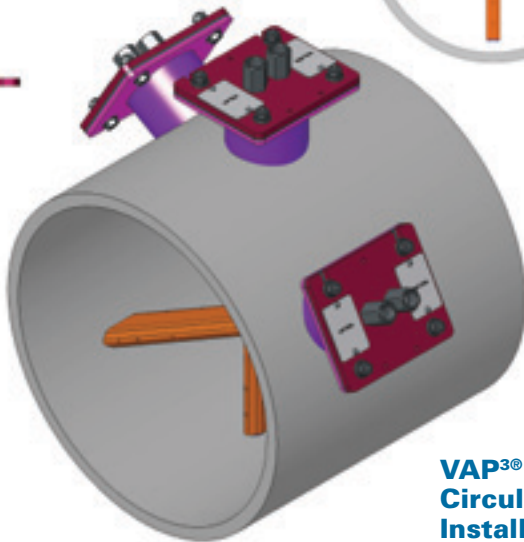

**VAP³ Pitots
Circular Duct
Installation
(isometric view)**

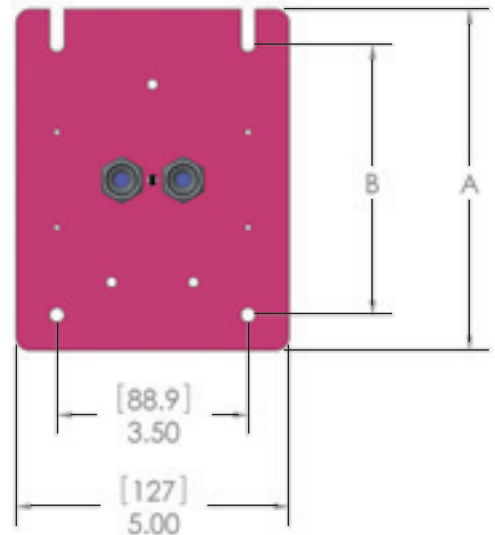

VAP³® SPECS, CONT.

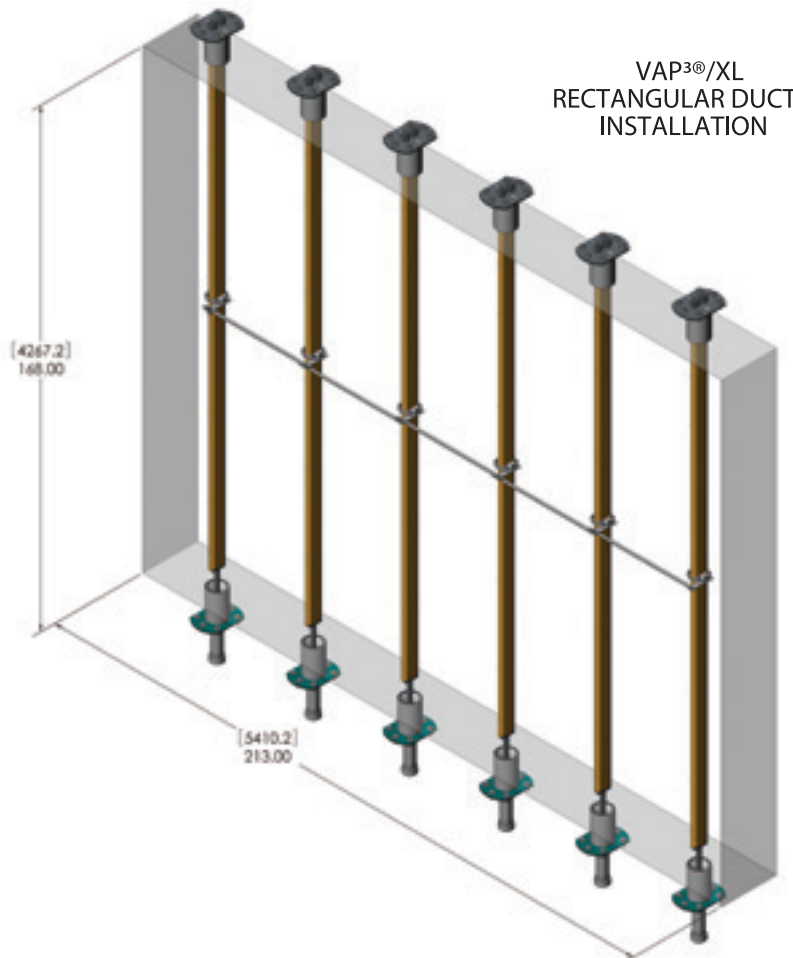
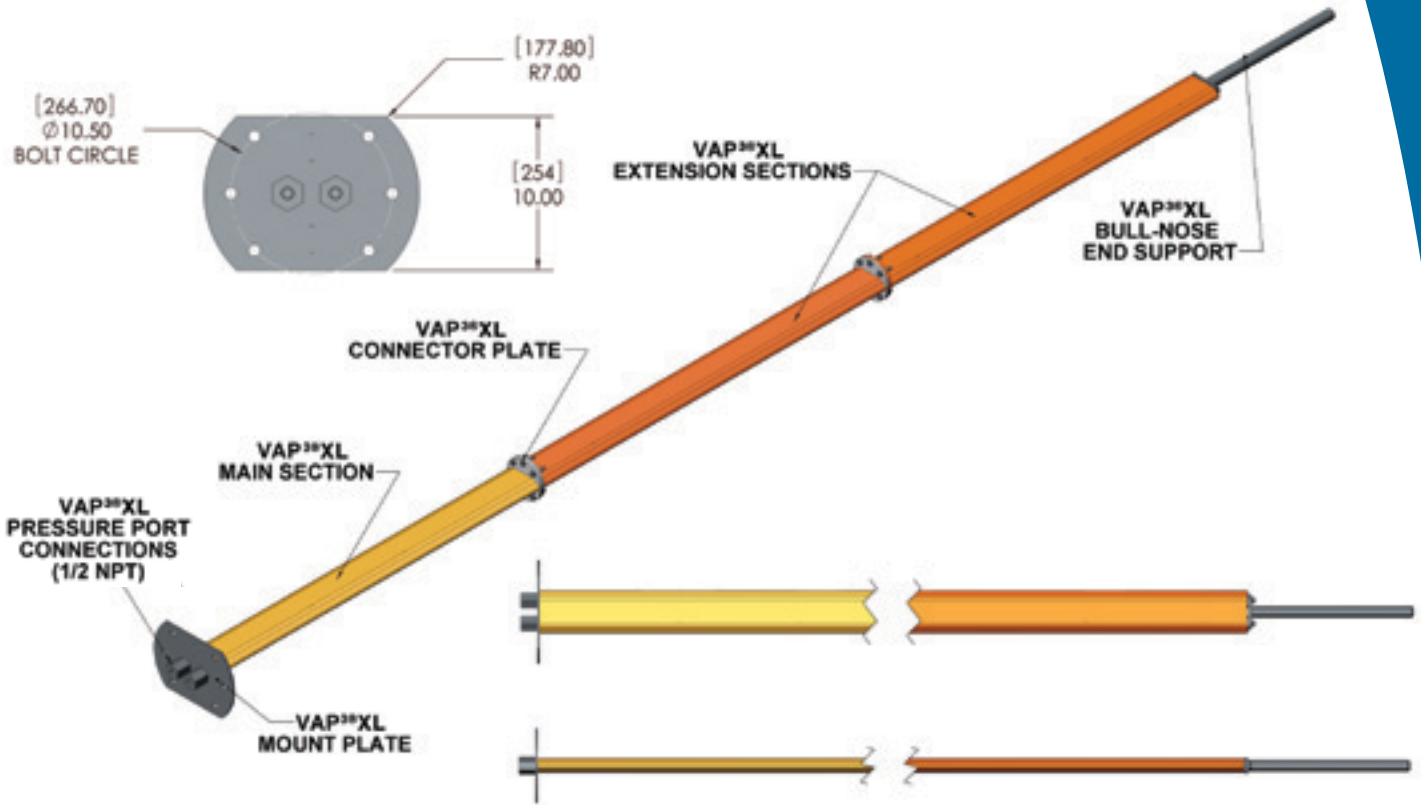

DETERMINING PRODUCT NUMBER

To determine your product number, simply note the option you need from each section below, and place that code in its corresponding box in the grid. For instance, if you have a clean-air application VAP³® for a round duct configuration, then fill in boxes D1 and D3 with the codes SA and RD, respectively. Complete the grid by continuing that pattern for each option.

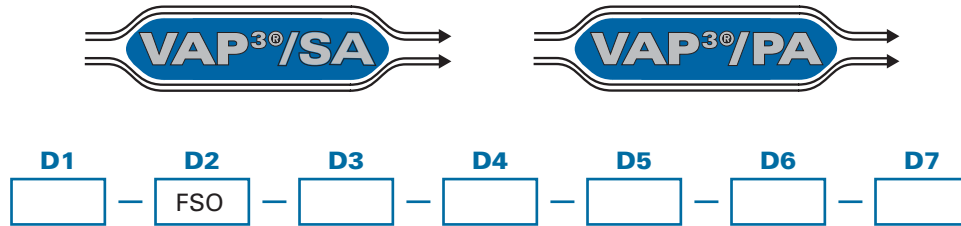

D1 Pitot Orientation

- SA Standard Application
- PA Particulate Application

D2 Probe Size

- # Factory-Selected Option (based on duct size)

D3 Duct Configuration

- RT Rectangular/Square (Flat Surface)
- RD Round (Curved Surface)

D4 Port Mounting Length

- NIP Direct Mount to Duct - No Mounting Port (Flat Surface only)
- 2IP 2" long Insertion Port; Port-mounted directly to duct
- 6IP 6" long Insertion Port; Port-mounted directly to duct
- EO Engineered-to-Order/Custom

D5 Pitot Mounting Plate

- 425 4.25" wide Mounting Plate, 1/4" thick, Anodized Aluminum, 15 PSI Rated
- 625 6.25" wide Mounting Plate, 1/4" thick, Anodized Aluminum, 15 PSI Rated
- 150 ANSI 150# Specified Mounting Flange, 2.5" pipe specification
- EO Engineered-to-Order/Custom

D6 End Support Type

- NS No End Support - Cantilever (Pitot length less than 34 ")
- BN Bull-Nose Support: 6" long support rod for Pitot length of 34" plus)
- EO Engineered-to-Order/Custom

D7 Additional Options (Add All You Require)

- NA None Selected
- HT1 Integral Heater Elements - 100 Watts/inch
- STF Integral Probe Stiffener - SS Stiffener inserted inside center section of pitot (contact EI)
- TS1 Integral Thermocouple mounted within pitot (includes Aluminum Termination Head)
- TS2 Integral Thermocouple mounted within pitot with Transmitter (included Aluminum Termination Head)
- EO Engineered-to-Order/Custom

Installation Notes for VAP³®

- Either VAP³®/PA or VAP³®/SA
- Probes mounted to duct through Insertion Port
- Bull-nose end support available for sizes over 34"
- Available in sizes from 4" to 112"; custom sizes are also available

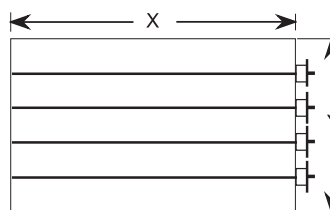
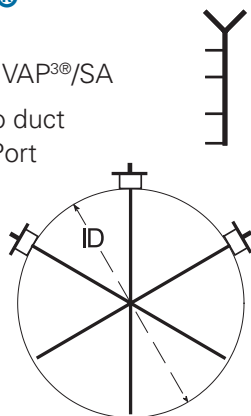

Round or Circular Ducts	
ID	Min. Qty.
3.5" to 8"	1
10" to 18"	2
20" to 116"	3

Rectangular or Square Ducts	
Y	Min. Qty.
6" to 8"	1
10" to 26"	2
28" to 36"	3
38" to 60"	4
62" to 116"	5
188" +	Consult factory

PRODUCT NUMBERS: DSV – DUCT SECTION VAP^{3®}



D1	Element Size	D3	Mat'l of Construction	D6	Gaskets
C6-C22	Circular: 6, 8, 10, 12, 14, 16, 18, 20, 22-inch nominal duct size; 12-inch overall length	304	304 Stainless Steel Duct Section	WS	FDA Approved White Silicone
C24-C36	Circular: 24, 26, 28, 30, 32, 34, 36-inch nominal duct size; 24-inch overall length	316	316 SS Duct Section	GR	Graphite
EO	Engineered-to-Order/Custom	AL	6061 Alumin. Duct Section	SW	Spiral Wound
		CS	Carbon Steel Duct Section	EO	Engineered-to-Order/Custom
D2	Pressure Rating	D4	Mounting Flange (see D2 for Pressure Rating)	D7	VAP^{3®} Configuration
LP	Low Pressure: Maximum Pressure 10 psig (0.7 bar); typically 16 gauge wall thickness	L1	Low Pressure: 0.125" thick Angle Ring Flange - STD Angle Ring Pattern	SA	Superior Accuracy for Clean Air Application
MP	Medium Pressure: Maximum Pressure 30 psig (2 bar); typically 12 gauge wall thickness	L2	Low Pressure: 0.250" thick Plate Flange; ANSI 150# Pattern	PA	Particulate Application
SP	Shock Pressure: Maximum Pressure 30 psig (2 bar); typically 12 gauge wall thickness with Shock (175 psig or 12 bar rated) flanges	M1	Medium Pressure: 0.375" thick Plate Flange; STD Angle Ring Pattern	EO	Engineered-to-Order/Custom
HP	High Pressure: Maximum Pressure 150 psig (10 bar); typically ANSI pressure rated piping	M2	Medium Pressure: 0.375" thick Plate Flange; ANSI 150# Pattern	D8	Additional Options (Add All You Require)
EO	Engineered-to-Order/Custom	H1	High Pressure: ANSI 150# Flange	NA	None Selected
		EO	Engineered-to-Order/Custom	TM	Mount for Temperature Sensor/Element (add'l specification required); 1/2 NPT Half Coupling
		D5	Factory Use	DM	Mount for Differential Pressure Transmitter (add'l specification required); requires Flange Mount on transmitter
		NA	Not Used	GM	Mount for Differential Pressure Gauge (add'l specification required); requires Surface Mounting Bracket on Pressure Gauge
		CFC	See Customer Flange Code for Engineered-to-order/Custom Flange; add to end of model number		

Installation Notes for DSV – Duct Section VAP^{3®}

- Either VAP^{3®}/PA or VAP^{3®}/SA
- Duct mounted measurement with VAP^{3®} Pitots installed in place, utilizing straightening vanes (without converging section of the High Beta[®])
- Available in sizes from 4 to 36" in 2-inch increments (custom sizes are available)
- Available in a number of material, flange, and pressure configurations
- Length (X) dependent on nominal diameter (Dn); Sizes 4" to 22", length is 12"; sizes 24" to 48", length is 24"

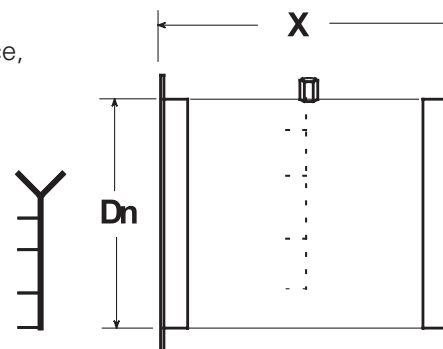

High Beta[®] Flow Conditioners

Air flow measurement is most accurate when the flow has no turbulent, reverse, and/or cyclonic flow patterns and is evenly profiled across the duct at the measurement point. The High Beta[®] flow conditioner is ideal for either new or retrofit process and power applications where insufficient straight duct runs are present and/or accuracy is required.

The High Beta[®] is designed for installations with relatively no straight duct run upstream and/or downstream and eliminates cyclonic, turbulent, and reverse flow at the point of measurement. There are many different variations of the High Beta[®] that include specific product features for the pharmaceutical, process, and power generating industries.

The High Beta[®] consists of a flanged 304 stainless steel duct section that can be inserted into either round or rectangular ducts. Within the High Beta[®] is housed an array of VAP^{3®} pitots. The VAP^{3®} provides an accurate differential pressure output, allowing for precise air flow measurement or control of your processes. The High Beta[®] is available with VAP^{3®}/SA or VAP^{3®}/PA pitots, for clean air applications or heavy particulate-laden applications, respectively. The High Beta[®] is erosion resistant and can handle typical process temperatures from -40° to 700° F.



Features and Benefits

- **Incorporates VAP^{3®} Pitots:** Optimizes accuracy
- **Integrated flow measurement:** Low-cost high-speed in-duct installation
- **Integral straightening vanes:** Stops cyclonic flow
- **High Beta[®] Ratio:** Low unrecovered pressure drop
- **Profiles flow for measurement:** Enables insertion near obstructions
- **Constant diameter in measurement area:** Accuracy/repeatability
- **Rugged:** Long Life - no maintenance

YOUR CHOICE OF APPLICATIONS

High Beta[®] Engineered (HBE)

The High Beta[®] Engineered is a custom-built solution to air flow measurement problems, ideal for power plants. Our engineers evaluate the customer's existing ductwork and can make recommendations using Computational Fluid Dynamics (CFD) Modeling. Flow profiles, temperature stratification and duct modifications can be modeled to improve measurement accuracy and process performance.

High Beta[®] Process Flow Element (HBP)

The High Beta[®] Process Flow Element is ideal for process applications where a high level of accuracy is crucial. The HBP is available in medium pressure with a 30 psig (2 bar) rating, and flanges can be shock rated if needed. The HBP is constructed of 304 stainless steel and has flange options determined from the pressure rating and material thickness. Gasket options are also available.



HIGH BETA® SPECS

Installation Notes for HBE

- Typically used in particulate-laden applications utilizing VAP³®/PA Pitots
- Engineered specifically for each application
- Can be installed inside round, square, or rectangular ducts
- Little or no upstream or downstream straight runs required
- Unrecovered pressure loss can be minimized
- Accuracy can be maximized by varying the Beta Ratio, Area Ratio, and Location within the duct
- Typically mounted inside the duct, to a mounting flange/plate welded to the duct
- Can be supplied inside a duct "spool" section to attach to an existing duct
- Can be engineered to fit in tight access areas by flanging the unit into sections that can be bolted or welded together in the duct
- For multiple HBE configurations, impulse lines are connected to a manifold block for simple customer connections

- Straightening vanes are standard in converging section

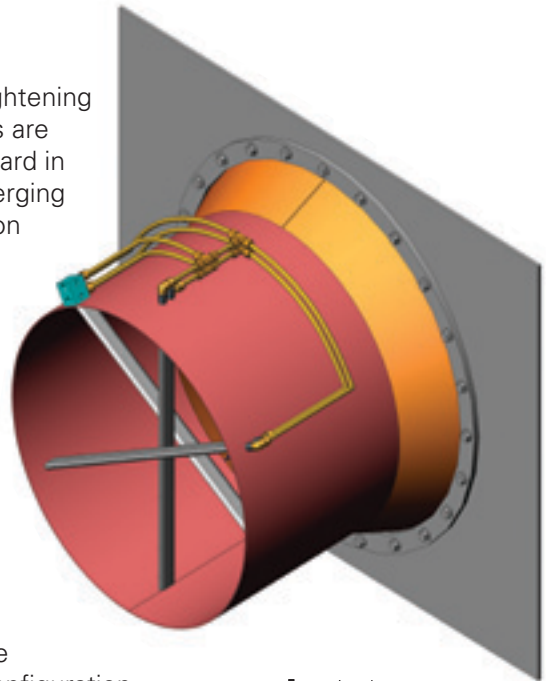

NOTE: To determine correct configuration and/or products for the application, CFD Modeling is recommended if upstream and downstream requirements are not met.



Installation Notes for HBP

- Typically used in clean-air applications utilizing VAP³®/SA Pitots, but can use VAP³®/PA Pitots as well
- High Beta[®] primarily for process facilities, such as pharmaceutical and chemical applications
- Available in a number of flange and pressure configurations (custom configurations available)
- Typical installation requires minimal 1 Diameter (Dn) upstream of unit
- Unrecovered pressure loss typically 30% of DP
- Calibration can be validated against traceable nozzles
- Available in sizes up to 36-inches. See model numbers.
- Customer connections outside spool section
- Standard integral straightening vanes

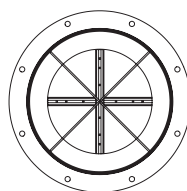
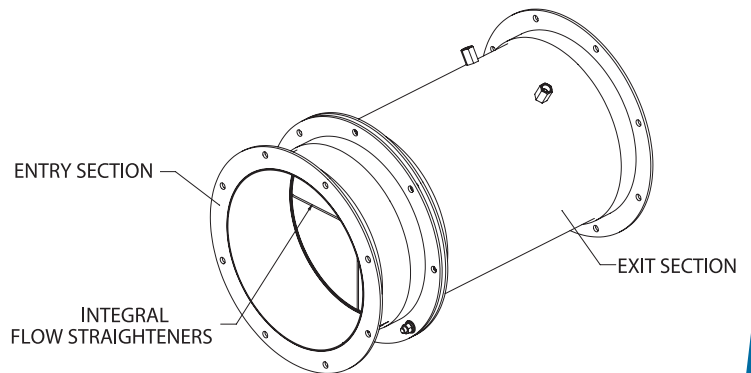

AIR FLOW DIRECTION →

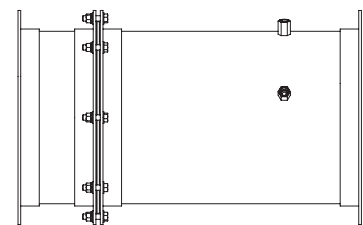

FOR MORE INFO, CALL 910.392.2490

Installation Guidelines

Determining Upstream Mounting Requirements

ASTM D 3154 Sec. 8.5, 8.6, & 8.7;
8.6 states that no velocity point can be less than 10% of the maximum velocity & 8.7 states that the flow vectors must be parallel to within 10° of the centerline of the duct

Round Duct Rule*: If the duct take-off, as indicated in the Upstream Plenum diagram, is round and the take-off is smaller in area than the supply header, and velocity in the supply header is 1/2 or more the velocity of the take-off, double the distance requirements if there are no straightening vanes.

Duct Velocity Rule*: If the average duct or measurement approach velocity is greater than 4000 ft/min, increase all distances proportionally (i.e. at 8000 ft/min double distances, at 2000 ft/min cut distances in half). **Note:** If the Duct is square or rectangular, then $D = (\text{Length} + \text{Width})/2$

* At Standard Conditions

Upstream Obstruction (minimum)

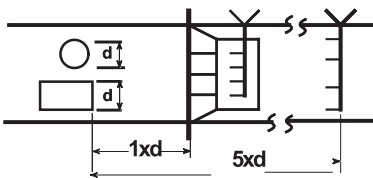

Upstream 45° or 90° (minimum – with or without turning vanes)

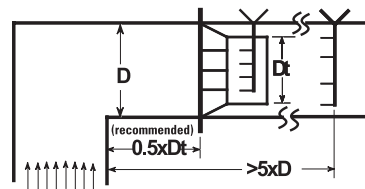

Upstream Tee (minimum)

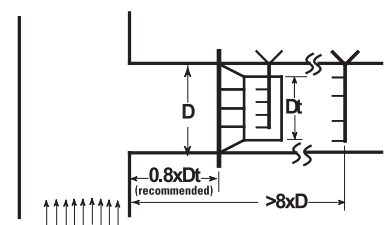

Upstream Damper (minimum)

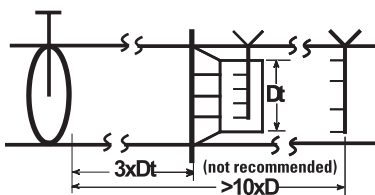

Upstream Radius 45° or 90° (minimum – with or without turning vanes)

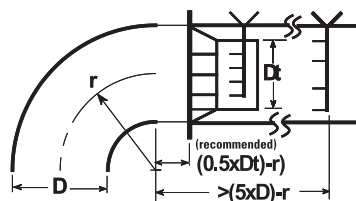

Upstream Fan (minimum)

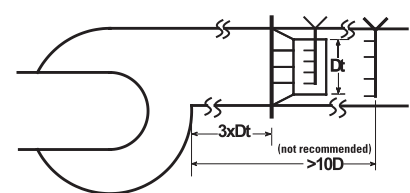

Upstream Plenum (minimum – take-off velocity is no more than 1/4 plenum velocity, otherwise use Upstream Tee)

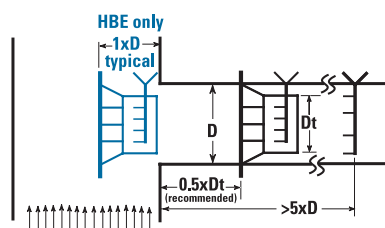

Upstream Take-off (minimum – take-off velocity is no more than measure velocity, otherwise use Upstream Tee)

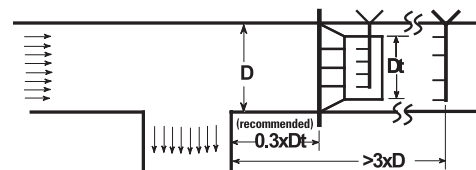

Determining Downstream Mounting Requirements

to meet ASTM D 3154 Sec. 8.5, 8.6, & 8.7

Downstream 90°
(minimum — with or without turning vanes)

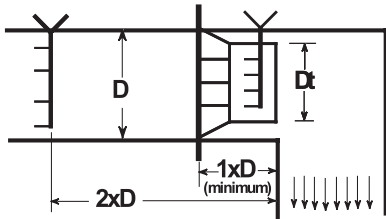

Downstream Damper (minimum)

note: measurement is from the leading edge of the damper in the full open position

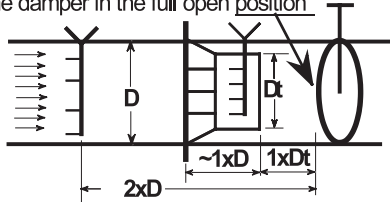

Downstream Fan (minimum)

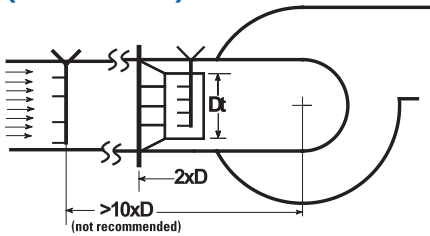

Downstream Radius 45° or 90° (minimum)

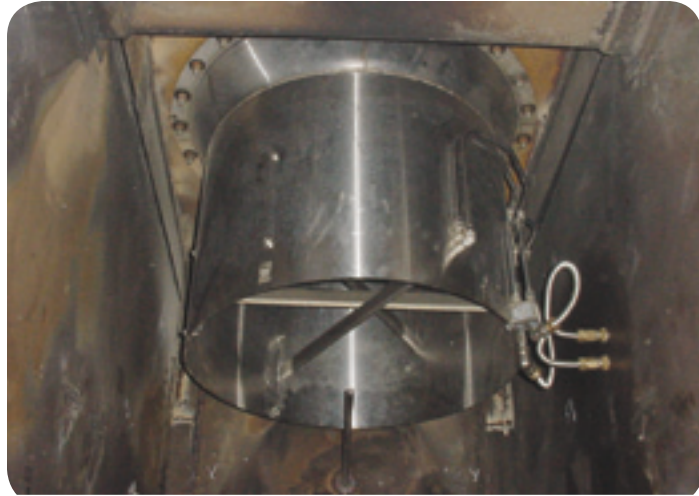
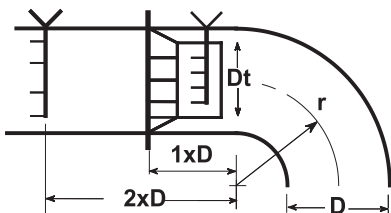

Installation of Eastern Instruments High Beta® in a rectangular duct



Installation of multiple High Beta® Elements within a rectangular duct, focusing on the straightening vanes

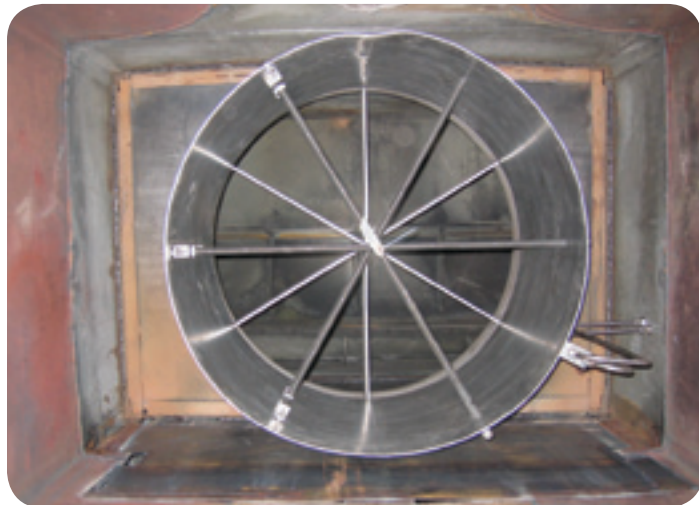

View of the Pitot array within the High Beta®

DETERMINING PRODUCT NUMBER: HBP

To determine your product number, simply note the option you need from each section below, and place that code in its corresponding box in the grid. For instance, if you'd like a High Beta® Process Flow Element for a 4" circular element, then fill in box D1 with the code C4. Complete the grid by continuing that pattern for each option.

D1	D2	D3	D4	D5	D6	D7	D8
<input type="text"/>	<input type="text"/>	<input type="text"/>	<input type="text"/>	<input type="text"/>	<input type="text"/>	<input type="text"/>	<input type="text"/>

D1 Element Size

- C4 Circular
4 inch nominal duct size;
7 inch overall length
- C6-C22 Circular
6, 8, 10, 12, 14, 16, 18, 20, 22 inch
nominal duct size;
24-1/4 inch overall length
- C24-C36 Circular
24, 26, 28, 30, 32, 34, 36 inch
nominal duct size;
36-1/4 inch overall length
- EO Engineered-to-Order/Custom

D2 Pressure Rating

- LP Low Pressure
Maximum Pressure 10 psig (0.7 bar);
typically 16 gauge wall thickness
- MP Medium Pressure
Maximum Pressure 30 psig (2 bar);
typically 12 gauge wall thickness
- SP Shock Pressure
Maximum Pressure 30 psig (2 bar);
typically 12 gauge wall thickness with
Shock (175 psig or 12 bar) rated flanges
- HP High Pressure
Maximum Pressure 150 psig (10 bar);
typically ANSI pressure rated piping
- EO Engineered-to-Order/Custom

D3 Material of Construction

- 304 304 Stainless Steel Outer Spool/Duct
Section; Internal High Beta® is 304 SS
- 316 316 Stainless Steel Outer Spool/Duct
Section; Internal High Beta® is 316 SS
- AL 6061 Aluminum Outer Spool/Duct Section;
Internal High Beta® is 304 SS
- CS Carbon Steel Outer Spool/Duct Section;
Internal High Beta® is 304 SS

D4 Mounting Flange

(see D2 Option for Pressure Rating)

- L1 Low Pressure - 0.125 inch thick Angle Ring
Flange; STD Angle Ring Pattern
- L2 Low Pressure - 0.250 inch thick Plate
Flange; ANSI 150# Pattern
- M1 Medium Pressure - 0.375 inch thick Plate
Flange; STD Angle Ring Pattern
- M2 Medium Pressure - 0.375 inch thick Plate
Flange; ANSI 150# Pattern
- H1 High Pressure - ANSI 150# Flange
- EO Engineered-to-order/Custom

D5 Factory Use

- NA Not Used
- CFC See Customer Flange Code for Engineered-
to-order/Custom Flange; Add to end of
model number

D6 Gaskets

- WS FDA Approved White Silicone
- GR Graphite
- SW Spiral Wound
- EO Engineered-to-Order/Custom

D7 VAP³® Configuration

- SA Superior Accuracy for Clean Air Application
- PA Particulate Application
- EO Engineered-to-order/Custom

D8 Additional Options (Add All You Require)

- NA None Selected
- TM Mount for Temperature Sensor/Element (add'l
specification required); 1/2 NPT Half Coupling
- DM Mount for Differential Pressure Transmitter
(additional specification required); requires
Flange Mount on transmitter
- GM Mount for Differential Pressure Gauge
(additional specification required); requires
Surface Mounting Bracket on Pressure Gauge

FOR MORE INFO, CALL 910.392.2490



Remote Electronics Packages

DPS: Differential Pressure System

The DPS, when coupled to the VAP³[®] pitot, is used to deliver flow measurement for process and power applications. The microprocessor-based flow transmitter consists of a differential pressure transmitter and flow processor. The system transmits an analog output signal that is proportional to flow. The processor enables the DPS to take a temperature and/or a duct static pressure input signal, providing a density-compensated output signal in wide range of flow units. With the fast scan time of the DPS and a selectable moving average of the display and output variables, the DPS can deliver a reliable, accurate signal, converting the fast response of the VAP³[®] pitot to the digital control systems of today.



DPU: Differential Pressure Unit

The DPU, when coupled to the VAP³[®] pitot is used to deliver accurate, dependable flow measurement in process and power applications. The Pressure and Flow Transmitter and Display Unit consists of a differential pressure transmitter and an optional display. The DPU can be configured to display differential pressure or flow rate and will transmit a 4-20mA analog output signal that is proportional to the displayed value. The DPU can also be configured to simply be an enclosed pressure unit with or without a display and transmit the actual differential pressure in a 4-20mA signal.



DPG: Differential Pressure Gauge

The DPG, when coupled to the VAP³[®] pitot, is used to deliver a reliable flow measurement for process and power applications. The Pressure and Flow Display consists of a differential pressure gauge manifolded within an industrial enclosure. It can be configured to display differential pressure in inches of H₂O, as well as flow rate in customer defined units. The unit is accurate to within +/- 2% and is suited for clean, dry, non-corrosive air. It is rated for internal pressures from -10 to 10 psig (-68.6 to 68.9 kPa) and temperatures from 20° to 140° F (-6.67° to 60° C). When just a differential pressure display is needed, the DPG is the ideal solution.



DETERMINING PRODUCT NUMBER: DPS

To determine your product number, simply note the option you need from each section below, and place that code in its corresponding box in the grid. For instance, if you'd like a DPS with a white painted carbon steel enclosure, then fill in box D1 with the code CS. Complete the grid by continuing that pattern for each option.

D1	D2	D3	D4	D5	D6	D7	D8
<input type="text"/>	<input type="text"/>	<input type="text"/>	<input type="text"/>	<input type="text"/>	<input type="text"/>	<input type="text"/>	<input type="text"/>

D1 Enclosure Type

- CS White Painted Carbon Steel Enclosure
- SS 304 Stainless Steel Enclosure
- EO Engineered-to-Order/Custom

D2 Input Power Supply

- N None -Requires 24 Vdc, 500 mA Isolated Power
- PS 85-264 VAC/46-67 Htz or 100-375 Vdc Input, 24-28 Vdc Output
- EO Engineered-to-Order/Custom

D3 Differential Pressure Transmitter Range

- N None - External Transmitter
- 10 0-10 inWC / 0-2500 Pa Max Span
- 5 0-5 inWC / 0-1250 Pa Max Span
- 2 0-2 inWC / 0-500 Pa Max Span
- 1 0-1 inWC / 0-250 Pa Max Span
- P5 0-0.50 inWC / 0-125 Pa Max Span
- P25 0-0.25 inWC / 0-62.5 Pa Max Span
- P1 0-0.10 inWC / 0-25 Pa Max Span

D4 Auxilliary Inputs (4-20mA)

- N None
- T Temperature (-103°F to 752°F)
- TP Temperature (-103°F to 752°F) and Absolute Pressure (Max. 30 psia)
- EO Engineered-to-Order/Custom

D5 Analog Outputs (4-20mA)

- N None
- R Flow Rate (isolated) - Current Sink
- R24 Flow Rate (isolated) - Sourced
- RT Flow Rate & Temperature [retransmitted] (isolated) - Sourced
- RTP Flow Rate, Temperature [retransmitted] and Absolute Pressure [retransmitted] (isolated) - Sourced
- EO Engineered-to-Order/Custom

D6 Relay Options

- N None
- RA High/Low Alarm based on Flow Rate
- TA High/Low Alarm based on Temperature
- EO Engineered-to-Order/Custom

D7 Factory Use

- N Not Applicable

D8 Programming Options

- N None
- DL Data Logging
- EO Engineered-to-Order/Custom



**FOR MORE
INFO, CALL
910.392.2490**

PRODUCT NUMBERS: DPU – DIFFERENTIAL PRESSURE UNIT



D1 Enclosure Type

- CS White Painted Carbon Steel Enclosure
- SS 304 Stainless Steel Enclosure
- EO Engineered-to-Order/Custom

D2 Display Hardware

- N No Display (Customer-Supplied 24Vdc; Used to power differential pressure transmitter; No Display Unit)
- 110 110 VAC / 60Hz Input Display Unit (24Vdc Supplied by Display Unit)
- 220 220 VAC / 50Hz Input Display Unit (24Vdc Supplied by Display Unit)
- 24 24Vdc Input Display Unit (Customer Supplied 24Vdc; Used to power differential pressure transmitter; LED Display)
- LP Loop Powered Display Unit (Customer Supplied 24Vdc; Used to power differential pressure transmitter; LCD Display)

D3 Differential Pressure Transmitter Range

(See D2: Options N and LP)

- N None - External Transmitter
- 10 0-10 inWC/0-2500 Pa Max Span
- 5 0-5 inWC/0-1250 Pa Max Span
- 2 0-2 inWC/0-500 Pa Max Span
- 1 0-1 inWC/0-250 Pa Max Span
- P5 0-0.50 inWC/0-125 Pa Max Span
- P25 0-0.25 inWC/0-62.5 Pa Max Span
- P1 0-0.10 inWC/0-25 Pa Max Span
- EO Engineered-to-Order/Custom

D4 Display Value & Analog Output (4-20mA)

- DP Differential Pressure Output Proportional to DP Range - See D2: Options N and LP
- P Differential Pressure Display & Output - Current Sink
- P24 Differential Pressure Display & Output - Sourced (PS common with DP Transmitter Source)
- R Flow Rate Display & Output - Current Sink
- R24 Flow Rate Display & Output - Sourced (PS common with DP Transmitter Source)

D5 Factory Use

- N Not Applicable

D6 Relay Options

- N None
- P High/Low Alarm based on Differential Pressure (requires D4 - Option P or P24)
- R High/Low Alarm based on Flow Rate (requires D4 - Option R or R24)



PRODUCT NUMBERS: DPG – DIFFERENTIAL PRESSURE GAUGE



D1 Enclosure Type

- CS White Painted Carbon Steel Encl.
- SS 304 Stainless Steel Enclosure
- EO Engineered-to-Order/Custom

D2 Diff. Press. Gauge Range

- 10 0-10 inWC/0-2500 Pa Max Span
- 8 0-8 inWC/0-2000 Pa Max Span
- 6 0-6 inWC/0-1500 Pa Max Span
- 5 0-5 inWC/0-1250 Pa Max Span
- 4 0-4 inWC/0-1000 Pa Max Span
- 3 0-3 inWC/0-700 Pa Max Span
- 2 0-2 inWC/0-500 Pa Max Span
- 1 0-1 inWC/0-250 Pa Max Span
- P5 0-0.50 inWC/0-125 Pa Max Span
- P25 0-0.25 inWC/0-62.5 Pa Max Span
- EO Engineered-to-Order/Custom

D3 Display Gauge

- ST STD - Inches of H2O
- CG Custom Gauge - Dual Gauge, Includes STD Inches of H2O + Customer Defined Flow Units

D4 Factory Use

- N Not Applicable

D5 Display Number

- 1 Single Display
- 2 Dual Display (both are same differential pressure range and have the same display gauge)
- EO Engineered-to-Order/Custom

Other Options

Line Mounted Purge (LMP)

The LMP is a continuous purge system intended to be used with VAP³ Pitots by Eastern Instruments. The LMP is designed to supply a continuous balanced flow of air through the impulse lines and out of the probes sensing ports during flow measurement. The unit consists of an anodized aluminum purge block and capillary/internal filter set with ports tapped to receive NPT fittings, an optional mounting bracket (ordered separately), and a filter assembly.

VAP³ Insertion Port with Blank-Off Plate (VIP)

The VAP³ Insertion Ports (VIP) are used to mount the VAP³ Pitots to the duct. They come in a variety of materials of construction and will

be configured to match the contour of the duct. Standard port lengths are 2 inches and 6 inches long, with the mounting plate size matching that of the pitot. They are supplied with a blank off plate to allow the user to have the ports welded to the duct prior to the installation of the VAP³ Pitots.

Remote Temperature Sensor (RTS)

The Remote Temperature Sensor (RTS) is a temperature-measuring device that can be remotely mounted to a duct or pipe via a half coupling. It is the perfect alternative when an integrated temperature option cannot be used with a VAP³ Pitot or when a High Beta[®] Flow-conditioning device is installed. When used with a DPS flow transmitter, the RTS can provide the temperature input when temperature and pressure correction are required.



DETERMINING PRODUCT NUMBER LMP

To determine your product number, simply note the option you need from each section below, and place that code in its corresponding box in the grid. For instance, if you'd like an LMP constructed of 304 stainless steel, then fill in box D1 with the code 304. Complete the grid by continuing that pattern for each option.

D1 D2 D3 D4 D5

□ — □ — □ — □ — □

D1 Material of Construction

- 304 304 Stainless Steel
- AL Anodized 6061 Aluminum
- EO Engineered-to-Order/Custom

D2 Range/Flow Setting

- # Set by Factory

D3 Purge Type

- PP Probe Purge - Mounted Near Probe Array
- DP Transmitter Purge - Mounted Near DP Transmitter

D4 Mounting

- LM Line Mounted
- BM Bracket Mounted
- PM Plate Mounted
- EO Engineered-to-Order/Custom

D5 Supply Filter Type

- F1 Line Filter - STD Capacity
- F2 Line Filter - HIGH Capacity



PRODUCT NUMBERS: VIP – VAP³® INSERTION PORT



D1 Material of Construction

304	304 Stainless Steel
316	316 Stainless Steel
AL	6061 Aluminum
CS	Carbon Steel
EO	Engineered-to-Order/Custom

D2 Duct (Port) Mounting Design

FT	Rectangular/Square (Flat Surface)
CS4	Round (Curved Surface); 4 inch radius
CS5	Round (Curved Surface); 5 inch radius
CS6	Round (Curved Surface); 6 inch radius
CS7	Round (Curved Surface); 7 inch radius
CS8	Round (Curved Surface); 8 inch radius
CS9	Round (Curved Surface); 9 inch radius
CS12	Round (Curved Surface); 12 inch radius
CS14	Round (Curved Surface); 14 inch radius
CS16	Round (Curved Surface); 16 inch radius
CS18	Round (Curved Surface); 18 inch radius
EO	Engineered-to-Order/Custom

D3 Port Mounting Length

2IP	2 inch long Insertion Port -Port Mounted directly to duct
6IP	6 inch long Insertion Port -Port Mounted directly to duct
EO	Engineered-to-Order/Custom

D4 Port Mounting Plate (must match probe)

425	4.25 inch wide Mounting Plate
625	6.25 inch wide Mounting Plate
150	ANSI 150# Specified Mounting Flange, 2.5" pipe specification (only available in 6 inch long port)
EO	Engineered-to-Order/Custom

D5 Port Type

IP	Insertion Port for mounting of probe to duct wall
BN	Bull-Nose Port for Bull-Nose Support Rod on end of probe
EO	Engineered-to-Order/Custom

PRODUCT NUMBERS: RTS – REMOTE TEMPERATURE SENSOR



D1 Element Size

#	Standard Sizes 2, 4, 6, 8, 10, 12 (all dimensions are in inches)
EO	Engineered-to-Order/Custom

D2 Thermocouple Type/Description

KG	Type K Thermocouple -Ground Junction
EO	Engineered-to-Order/Custom

D3 Material of Construction (1/4" Diameter Sheath)

IN	Inconel Thermocouple Sheath
SS	304 Stainless Steel Thermocouple Sheath

D4 Coupling Material of Construction (1/2 coupling -1/2" NPT thread)

AL	Aluminum
CS	Carbon Steel
SS	Stainless Steel
EO	Engineered-to-Order/Custom

D5 Neck Length

#	Standard Sizes 2, 4, 6, 8, 10, 12 (all dimensions are in inches)
EO	Engineered-to-Order/Custom



**EASTERN
INSTRUMENTS**

Copyright 2008 Eastern Instruments

Protected by US Patents 5,402,687; 5,753,825 and 7,228,750 B2.
Other patents pending.

**416 Landmark Drive
Wilmington, NC 28412
Phone: 910.392.2490
Fax: 910.392.2123**

www.easterninstruments.com